

High-frequency modeling for hairpin windings

Centre for Mechatronics and Hybrid Technology
Mechanical Engineering, McMaster University
Yu (Joe) Zhang

EECOMOBILITY (ORF) &
HEVPD&D CREATE

EXPERIMENT

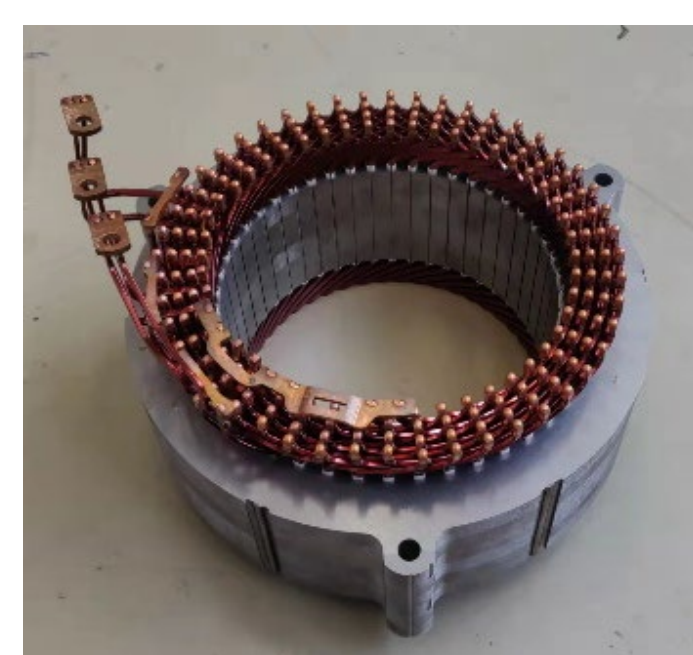
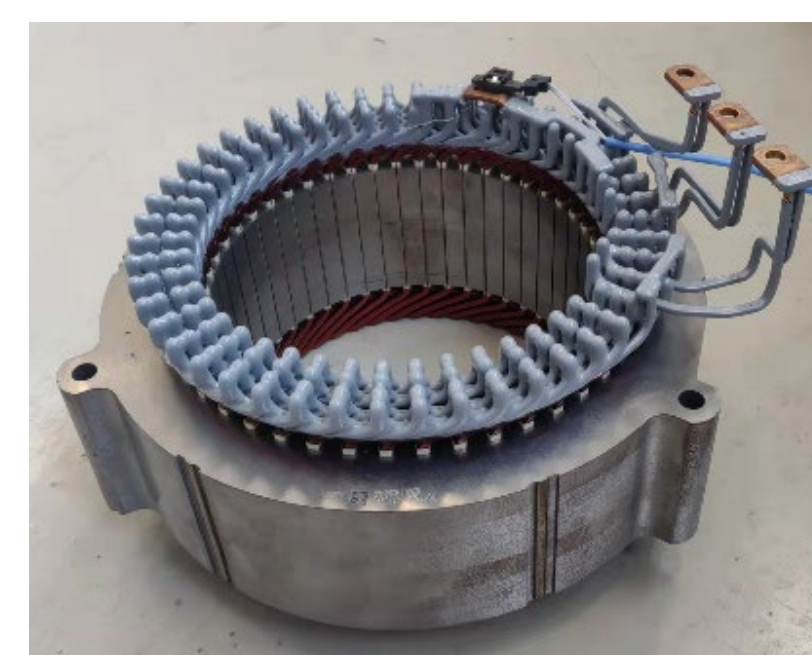

(A) Stator with epoxy

(B) Stator without epoxy

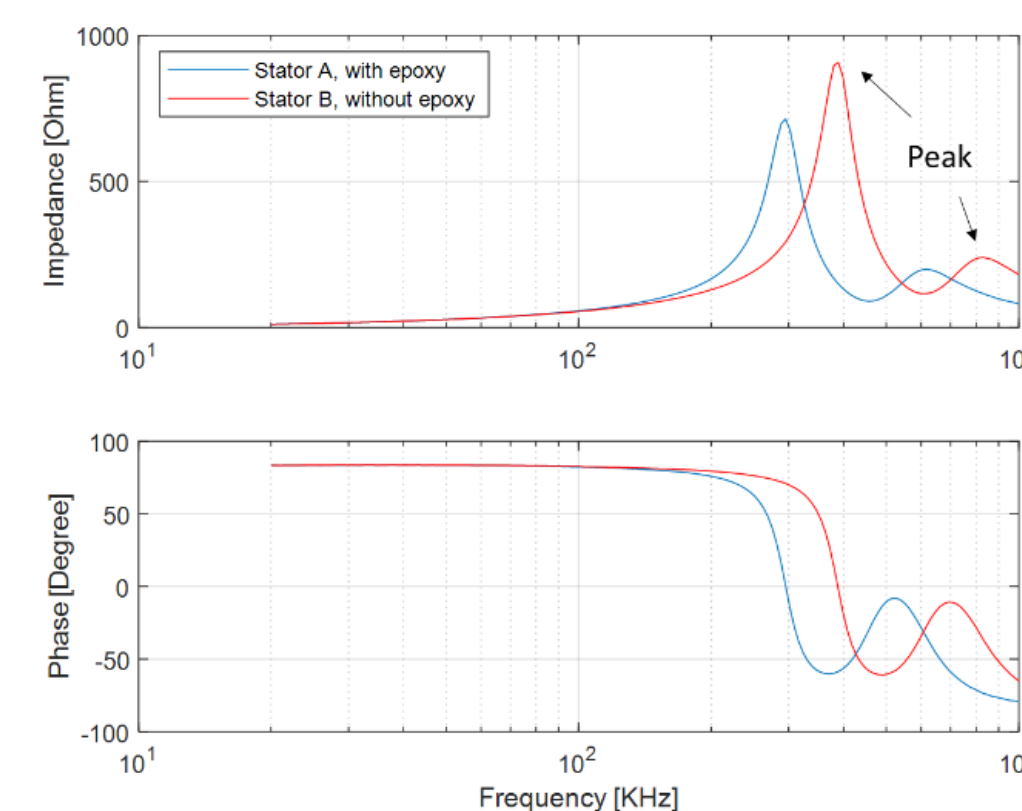
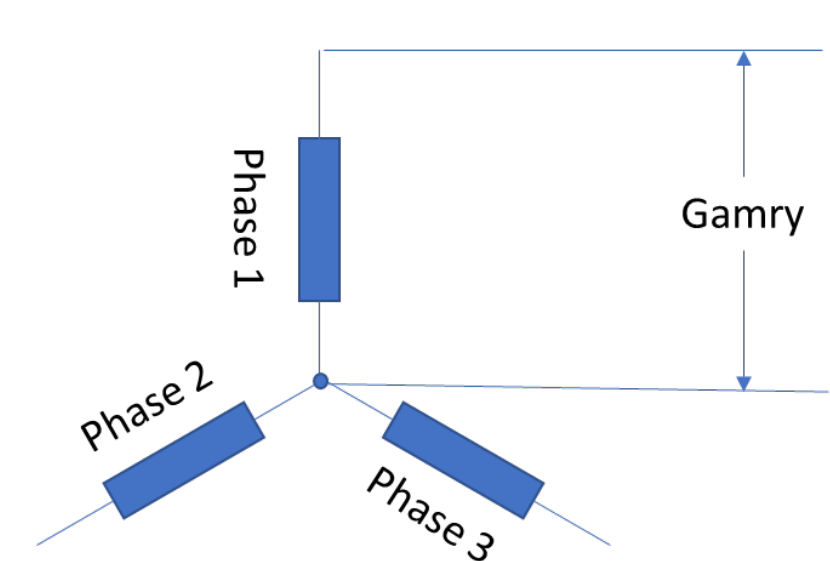

Difference:

- Impedance magnitude
- Peak frequency

SYSTEM IDENTIFICATION

$$Z = F(R_1, R_{C1}, R_{L1}, R_2, R_{C2}, R_{L2}, L_1, L_2, L_P, f)$$

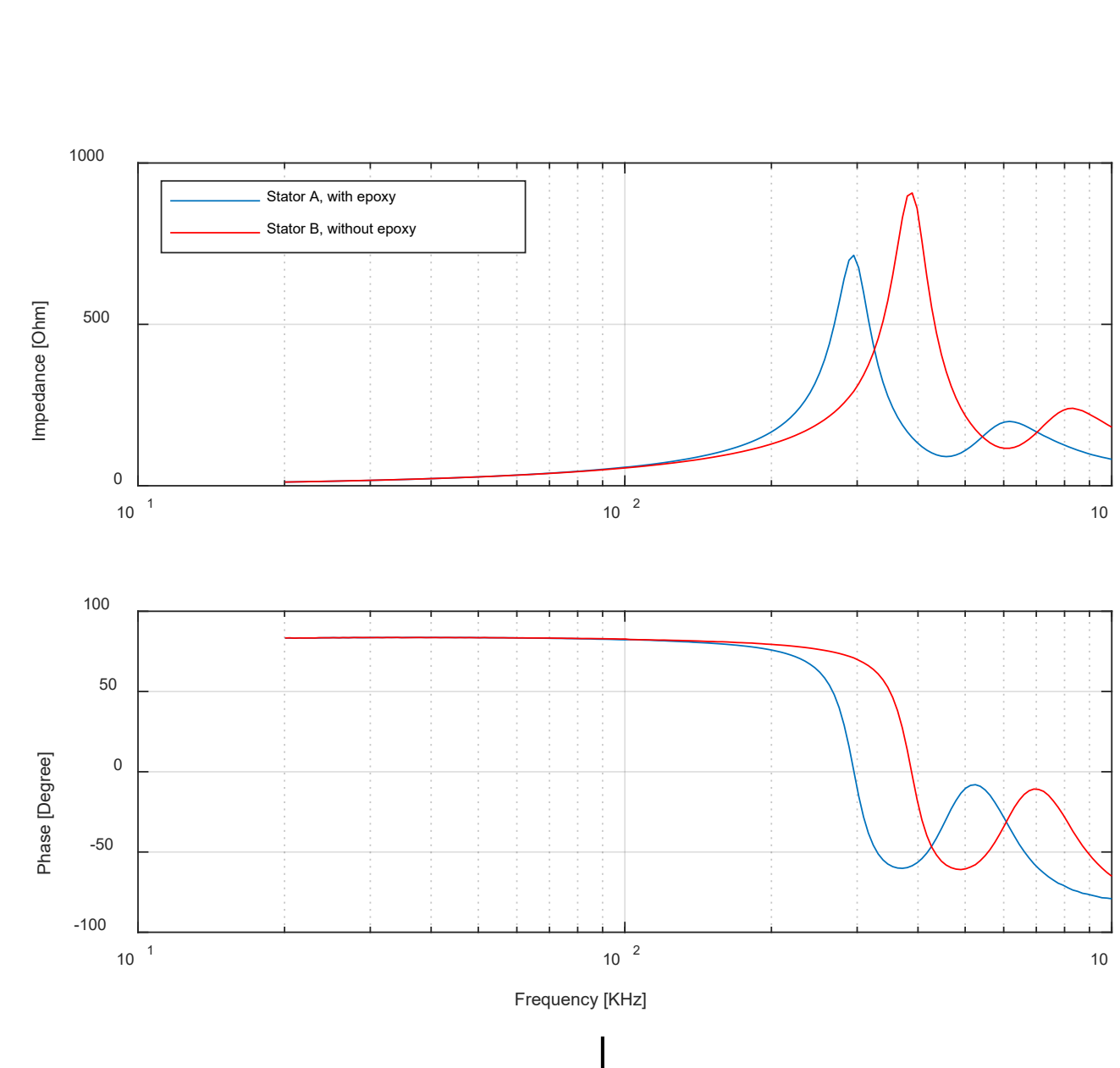

- Particle Swarm Optimization (PSO)
- an optimization algorithm
- Estimate each parameter within equivalent circuit

Symbol	R_1	R_{C1}	R_{L1}	R_2	R_{C2}	R_{L2}	L_1	L_2	L_P
Unit	Ω	Ω	Ω	Ω	Ω	Ω	H	H	H
Upper bound	1E4	1E2	1E2	1E4	1E2	1E2	1	1	1
Lower bound	1E2	1E-10	1E-10	1E2	1E-10	1E-10	1E-8	1E-8	1E-8

CONVENTIONAL MODEL

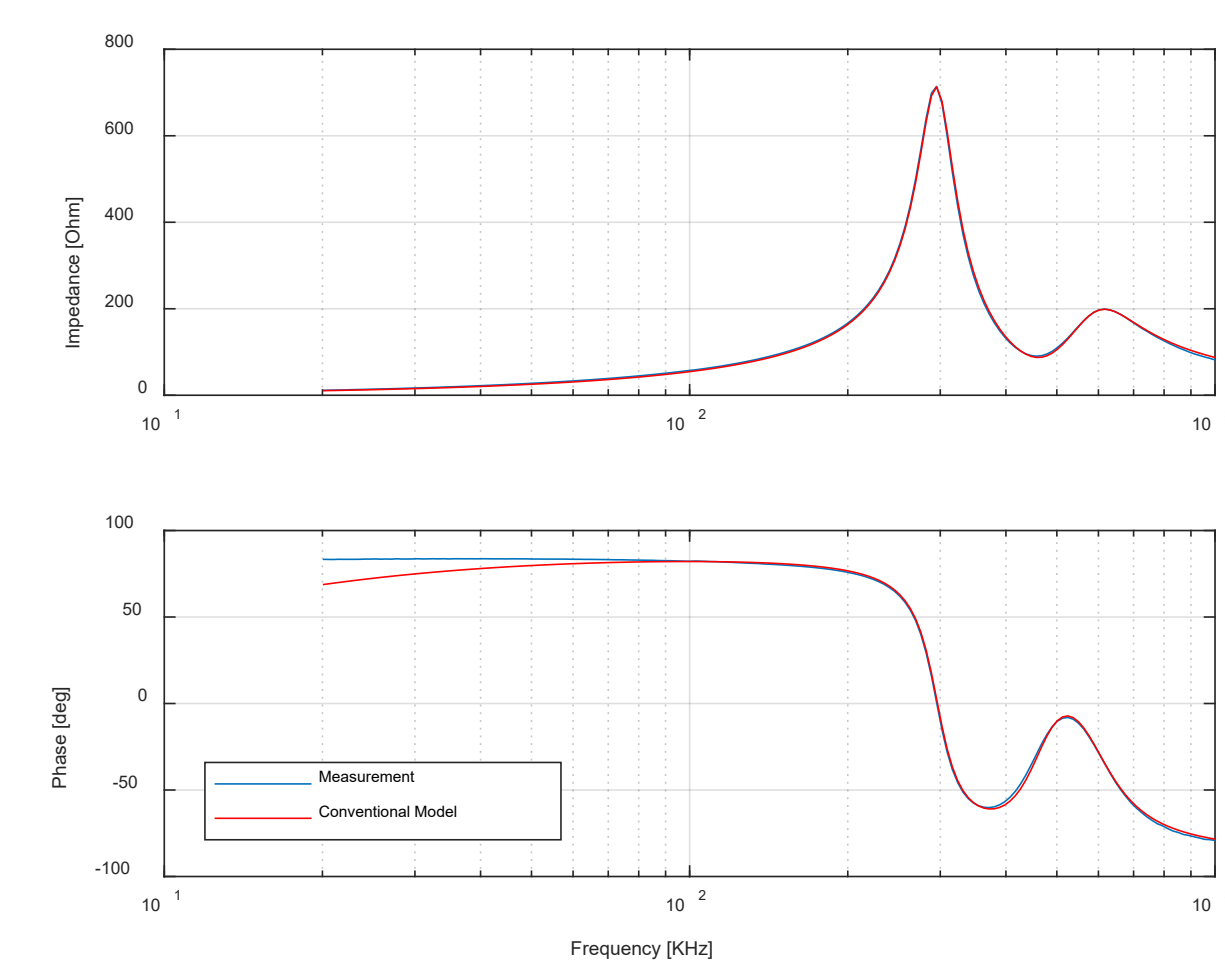
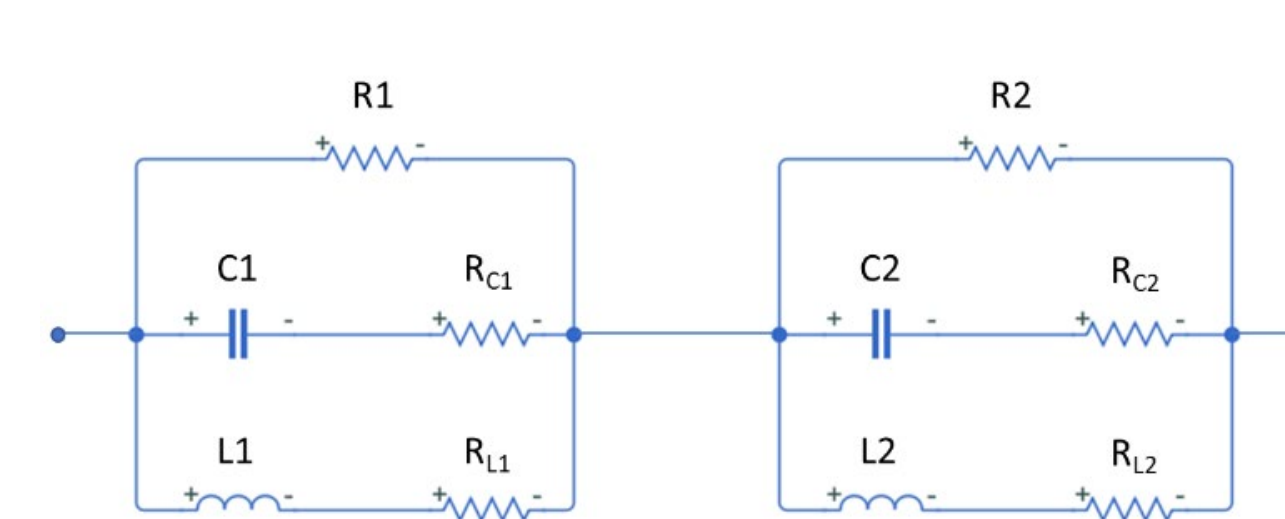

Above 100 KHz

- Good match
- 2nd order model
- Two resonance frequencies ω_1 and ω_2

$$\omega_1^2 = \frac{1}{L_1 C_1}$$

$$\omega_2^2 = \frac{1}{L_2 C_2}$$

Below 100 KHz

- Clear discrepancy
- Induction L variation
- Resistance R_L variation
- Must introduce many variables

$$L_{var} = a_1 \times (f)^{a_2}$$

$$R_{Lvar-low} = a_3 \times (f)^2 + a_4 \times f + a_5$$

$$R_{Lvar-high} = a_6 \times \sqrt{f + a_7}$$

RESULT

Symbol	R_1	R_{C1}	R_{L1}	R_2	R_{C2}	R_{L2}	L_1	L_2	L_P	Optimization error
Unit	Ω	Ω	Ω	Ω	Ω	Ω	H	H	H	
Stator A, With epoxy										
Phase 1	890.71	1.08E-5	4.14	177.74	0.5	0.61	1.64E-5	6.19E-5	1.13E-5	1894
Phase 2	966.12	0.54	4.81	175.79	0.33	0.77	1.6E-5	6.16E-5	1.08E-5	1768
Phase 3	940.43	1E-10	5.1	179.19	0.77	1.03	1.6E-5	6.15E-5	0.97E-5	1058
Average	932.42	0.18	4.68	177.57	0.53	0.81	1.61E-5	6.17E-5	1.06E-5	
Stator B, Without epoxy										
Phase 1	1261.6	0.0068	7.42	210.32	0.45	1.06	1.62E-5	5.99E-5	1.13E-5	3353
Phase 2	1559.3	1.49	9.35	201.46	7.05E-5	1.06	1.54E-5	5.94E-5	1.25E-5	3002
Phase 3	1528.3	0.87	9.6	201.39	2.33E-8	1.08	1.56E-5	5.91E-5	1.25E-5	1525
Average	1449.8	0.79	8.79	204.4	0.15	1.07	1.57E-5	5.95E-5	1.21E-5	

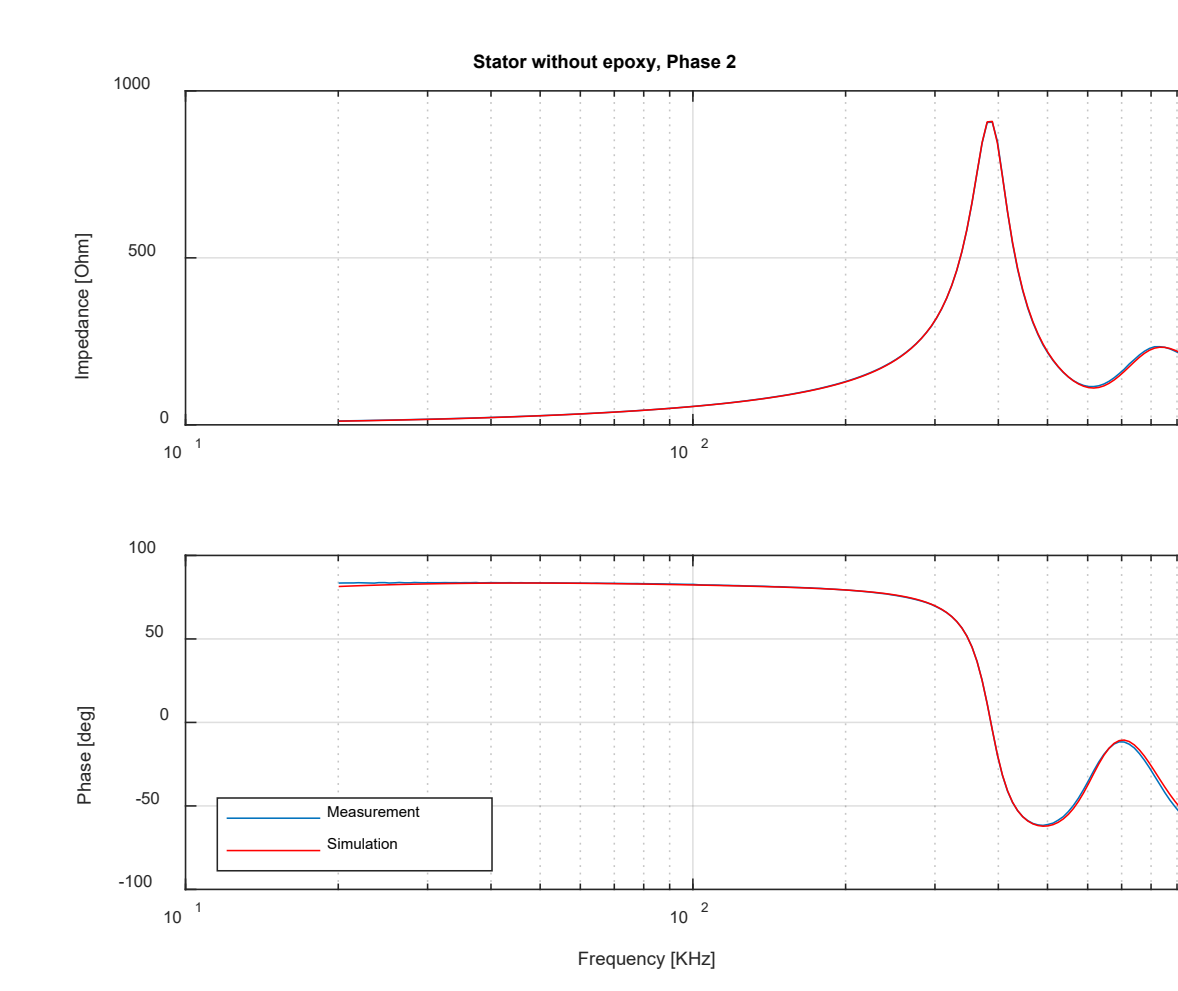
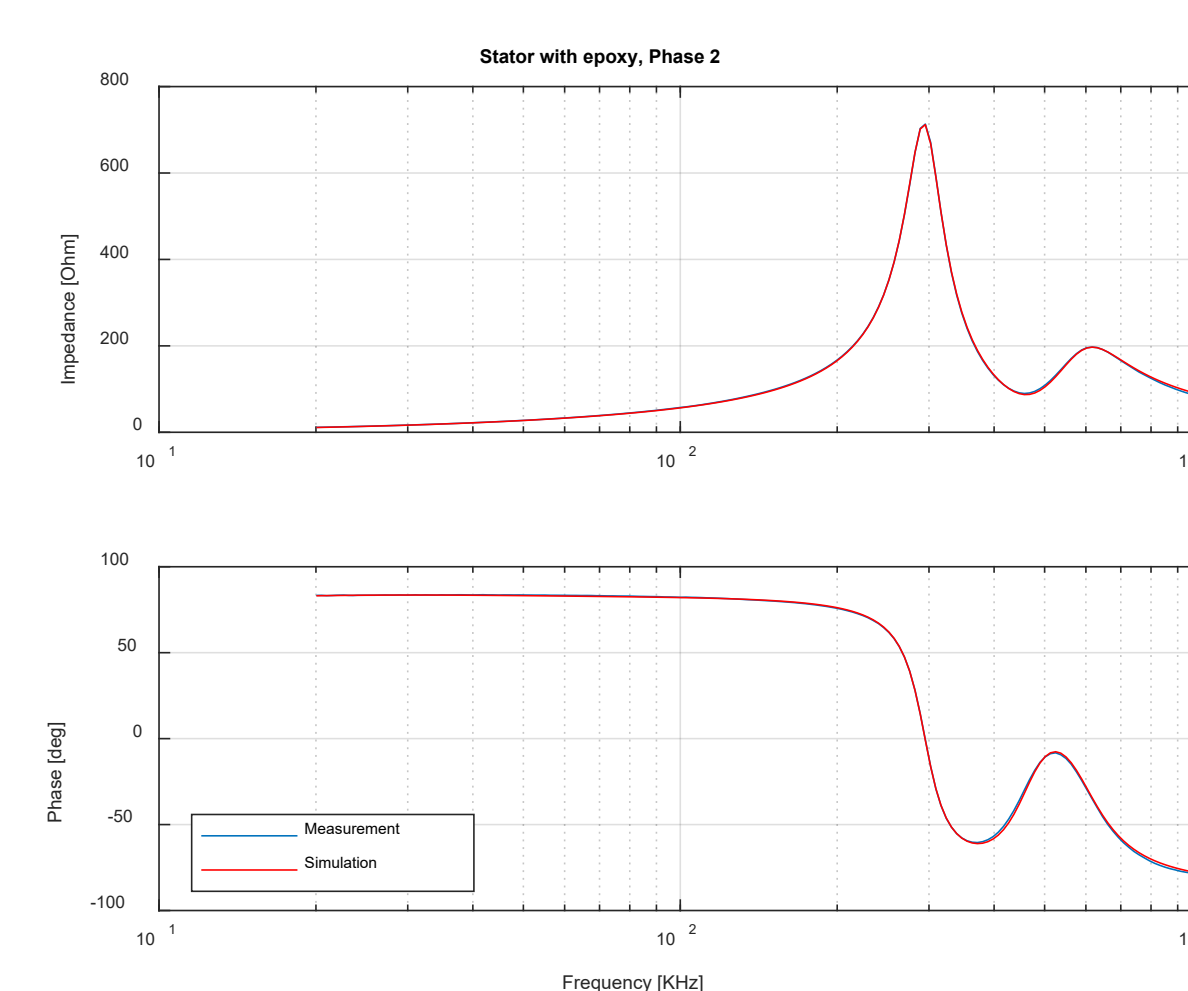

NOVEL HIGH-FREQUENCY MODEL

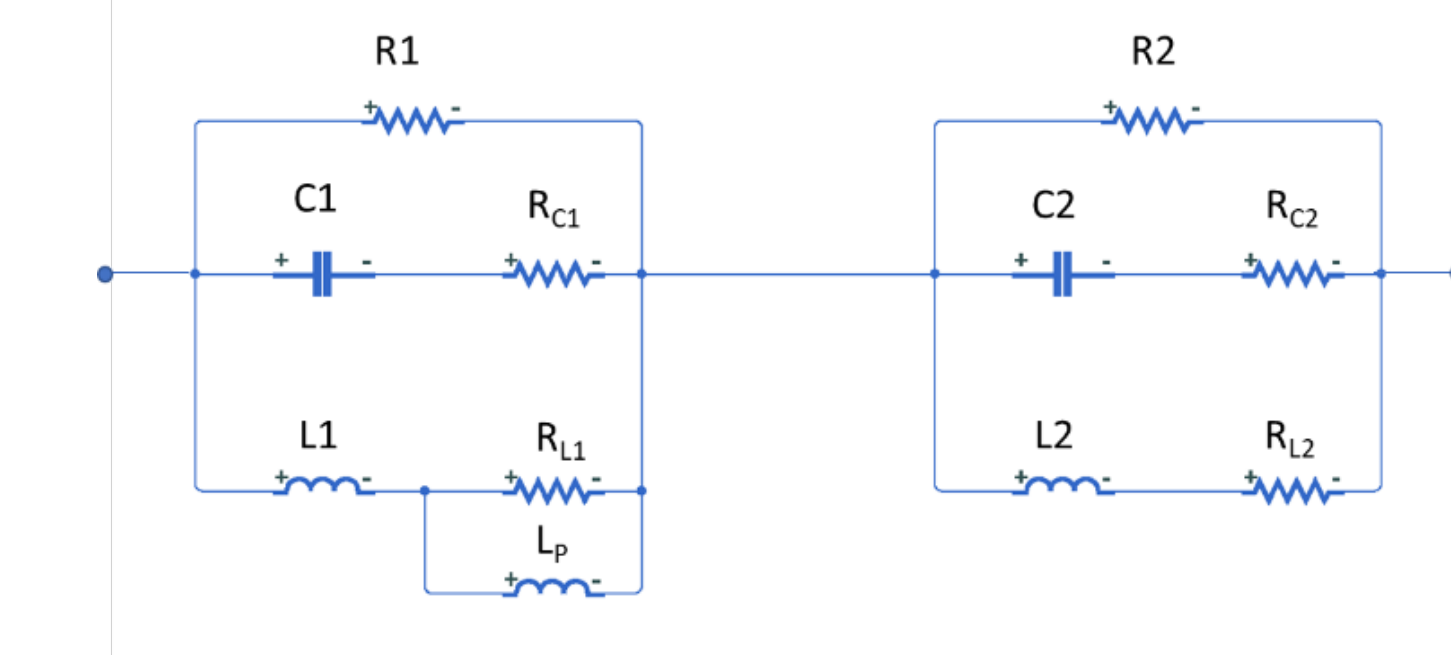

$$Z = \frac{1}{R_1 + \frac{1}{2\pi f L_1 i} + \frac{1}{\frac{1}{R_{L1} + 2\pi f L_P i} + \frac{1}{2\pi f C_1 i} + R_{C1}}} + \frac{1}{R_2 + \frac{1}{2\pi f L_2 i} + R_{L2} + \frac{1}{2\pi f C_2 i} + R_{C2}}$$

- L_1 and L_2 : inductance
- C_1 and C_2 : capacitance
- L_P : skin and proximity effects
- R_1 and R_2 : dissipative effects caused by iron losses
- R_{C1} and R_{C2} : dissipative phenomena due to high frequency capacitive currents
- R_{L1} and R_{L2} : the winding resistances

ANALYSIS

Physical meaning

- R_1 and R_2 : represent dissipative phenomena due to eddy currents in windings and laminated iron core. Since there is no epoxy in stator B, it has more magnetic flux penetration into the iron core. There generates more eddy current within the iron core, resulting in more dissipative phenomena.
- L_1 and L_2 : related to resonance frequencies ω_1 and ω_2 . Smaller ω values lead to bigger L values

R_1, R_2, L_1 and L_2 values

- converge to a small range within stators (with epoxy);
- have large discrepancies from the stator without epoxy;
- numerically reflect the impact of epoxy.

Conclusion:

- Novel high-frequency model for a hairpin-based winding phase within BLDC
- Includes the skin and proximity effects
- Significantly reduces the model complexity
- Numerically reflects the impact of epoxy
- Presents physical meanings