

# Model based Fault Detection and Diagnosis on Alternators

Centre for Mechatronics and Hybrid Technology  
Mechanical Engineering McMaster University  
Nicholas D'Aquila

EECOMOBILITY (ORF) &  
HEVPD&D CREATE

## What is an Alternator?

### Electromagnetic Induction

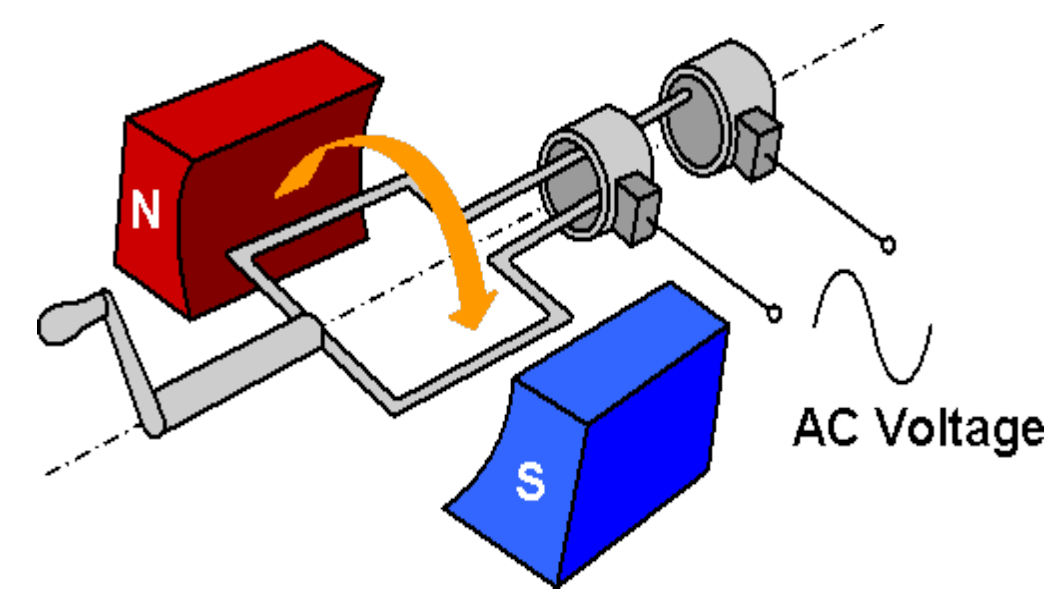

Automotive alternators are now used to charge the car battery as well as power the electrical systems in cars, such as radio, electric wipers, and other accessories. Alternators are from a branch of electric machines called synchronous generators. Synchronous generators use principles of electromagnetic induction to convert mechanical energy into electrical energy.

### Convert AC to DC

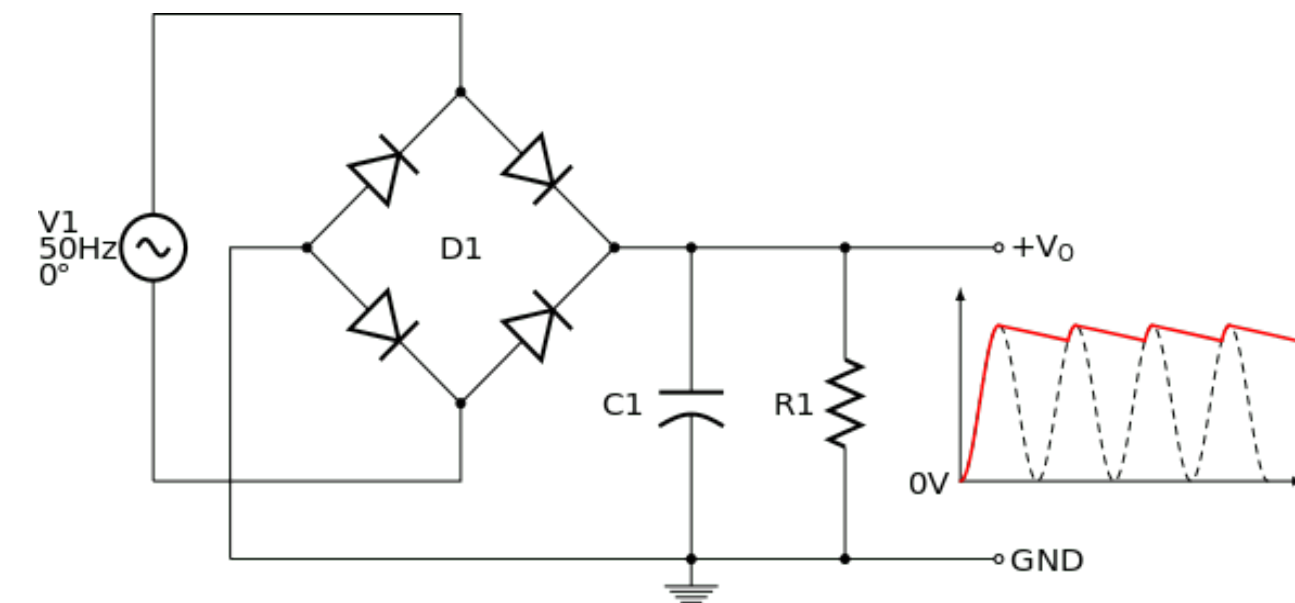

The typical automotive alternator generates a 3 phase AC power supply with the car engine acting as the prime mover. The devices in the car's electrical system need DC current to operate correctly. A diode rectifier bridge is an array of semiconductor diodes that can convert an AC supply to a DC supply. The three phases of the alternator are connected to a diode rectifier bridge, and the output of the system is dispersed to the electronics within the car.

### Supply Power to Vehicle's Electronics



The alternator's rotor windings are externally excited by the car battery as it is more cost effective and allows for voltage regulator control. The emf that the alternator generates is a function of rotor speed. Therefore, if the car is going very slow there will not be enough power to supply to all the electronics; conversely, if the car is going too fast the electronics are at risk of overvoltage. To manage this, an Automatic Voltage Regulator (AVR) is placed on the rotor windings to lower or raise the output in order to keep a constant voltage within the electrical system.

## Modelling an Alternator

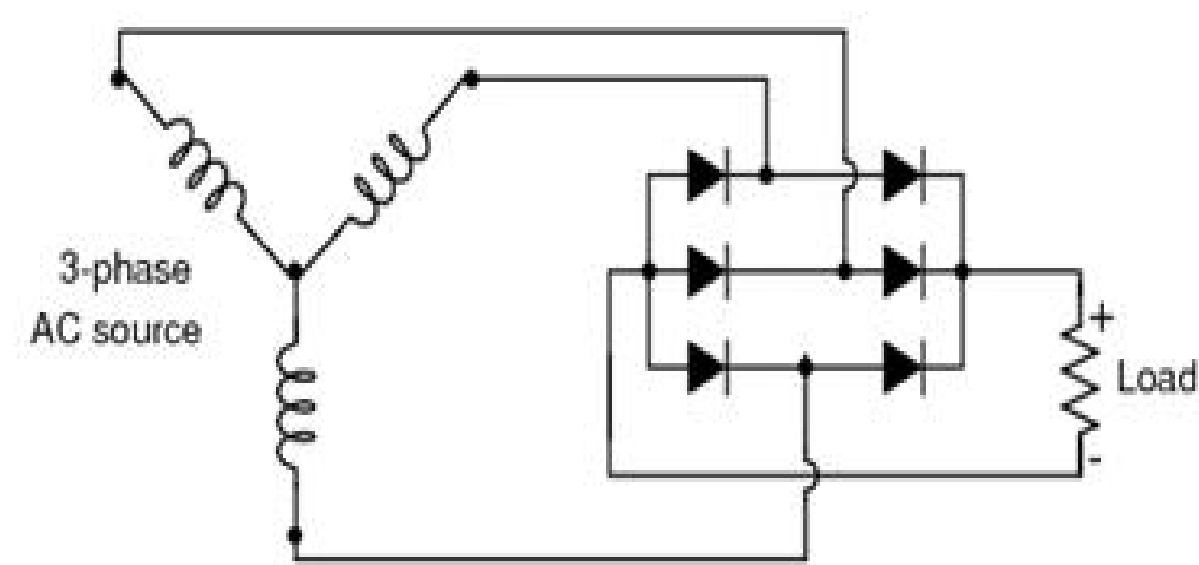

### Flux Linkage-Current Relationship

$$\begin{aligned}\lambda_a &= -L_a I_a - L_{ab} I_b - L_{ac} I_c + L_{af}(\theta_e) I_f \\ \lambda_b &= -L_{ba} I_a - L_b I_b - L_{bc} I_c + L_{bf}(\theta_e) I_f \\ \lambda_c &= -L_{ca} I_a - L_{cb} I_b - L_c I_c + L_{cf}(\theta_e) I_f \\ \lambda_f &= L_f I_f - L_{fa}(\theta_e) I_a - L_{fb}(\theta_e) I_b - L_{fc}(\theta_e) I_c\end{aligned}$$

Where,

$$\begin{aligned}L_{af}(\theta_e) &= L_{fa}(\theta_e) I_f = M \cos(\theta_e) \\ L_{bf}(\theta_e) &= L_{fb}(\theta_e) I_f = M \cos(\theta_e + \varphi) \\ L_{cf}(\theta_e) &= L_{fc}(\theta_e) I_f = M \cos(\theta_e - \varphi)\end{aligned}$$

IEEE has pre-defined models to describe characteristics of a synchronous generators such as phase voltage, phase current, field current, etc. For industrial use, it is important to consider factors such as calculation speed, difficulty to parameterize, difficulty to explain to operator of testing machine. Therefore, the most efficient model in this environment is the simplest system of equations that can capture the values important to the operator. A flux-current relationship and corresponding voltage equations are extracted from the principles of electromagnetic induction.

### Voltage Equations

$$\begin{aligned}V_a &= -RI_a + \frac{d\lambda_a}{dt} \\ V_b &= -RI_b + \frac{d\lambda_b}{dt} \\ V_c &= -RI_c + \frac{d\lambda_c}{dt} \\ V_f &= -RI_f + \frac{d\lambda_f}{dt}\end{aligned}$$

### Final Equations

Combining the above equations, the following equations are generated:

$$\begin{aligned}i &= -L^{-1}(RI + V) + L^{-1}\left(\frac{d}{dt} L_f(\theta_e)\omega_e I_f + L_f(\theta_e) \dot{I}_f\right) \\ i_f &= -\frac{R_f}{L_f} I_f - \frac{1}{L_f} V_f + \frac{1}{L_f}\left(\frac{d}{dt} L_f(\theta_e)\omega_e I + L_f^T(\theta_e) \dot{i}\right)\end{aligned}$$

### Calculating DC Current

These equations capture the values of the phase currents that can be used to detect alternator faults. To model the ripple current, the dot product must be taken between the phase currents and the diode switching state vector. In order to keep a non-negative DC value, the diode switching state of a phase can either be ON (1), OFF (0), or REVERSE (-1).

$I_{dc} = g_a I_a + g_b I_b + g_c I_c$ , where  $g_i$  is the phase diode's switching state.

### Output DC Current

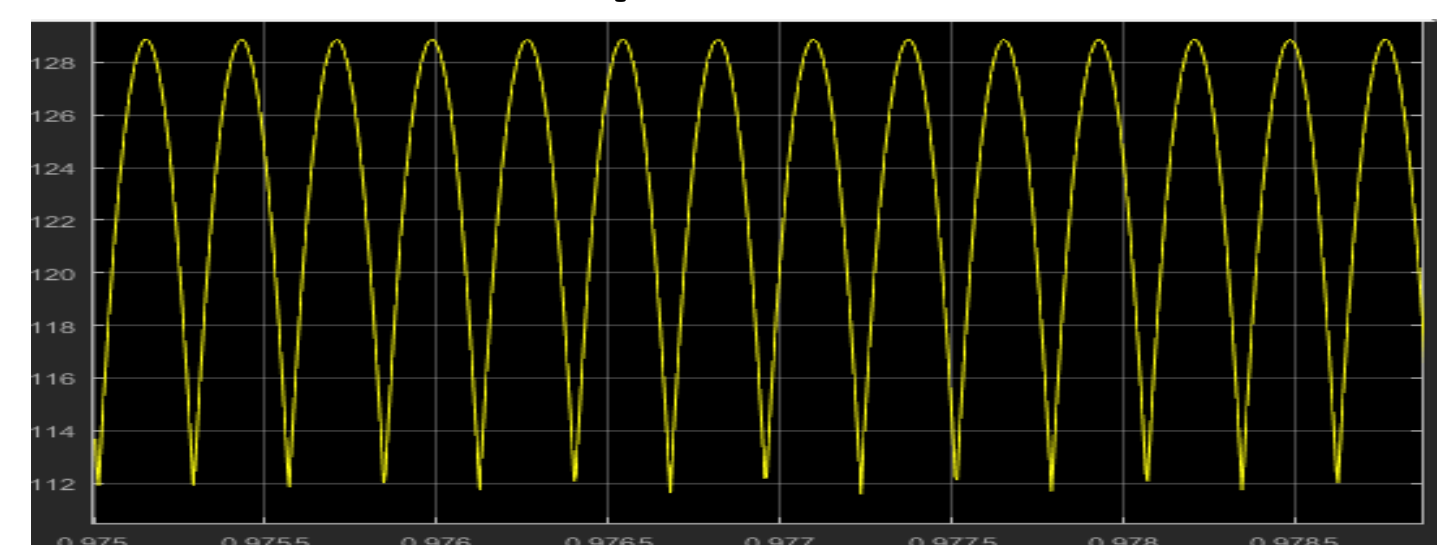

## Common Alternator Faults

### Open Diode Rectifier Fault



this is a failure of diodes in the three phase bridge rectifier. If one diode fails, the output will be unbalanced by the loss of that phase. This fault results in a large ripple in the output voltage and current. With inconsistent voltage and the introduction of voltage spikes, the electronics in the system become at risk.

### Belt Slip Fault



Occurs when the alternator belt does not have the proper tension to keep the alternator pulley rotating synchronously within the engine shaft. This fault results in decreased alternator output voltage, which the AVR attempts to stabilize by increasing the field voltage.

### AVR Under-Voltage Fault



The AVR has a reference voltage that the alternator's output should always be (within a certain tolerance). This reference voltage determines if the excitation voltage should increase or decrease in order to match the demand from the electronics in the system. A voltage regulator fault can be a reduction in the reference voltage causing the electrical system to be underpowered to match the lower reference.

### AVR Over-Voltage Fault



Even more dangerous, a voltage regulator fault can be an increase or bypass of the reference voltage causing the AVR to not decrease the excitation winding at high speeds leading to overvoltage. Overvoltage can also come in the form of the alternator disconnecting from the system. In both scenarios, the electrical system will be at risk of damaged circuitry.

## Model Based Fault Detection and Diagnosis

### Pass/Fail Testing with No Diagnosis

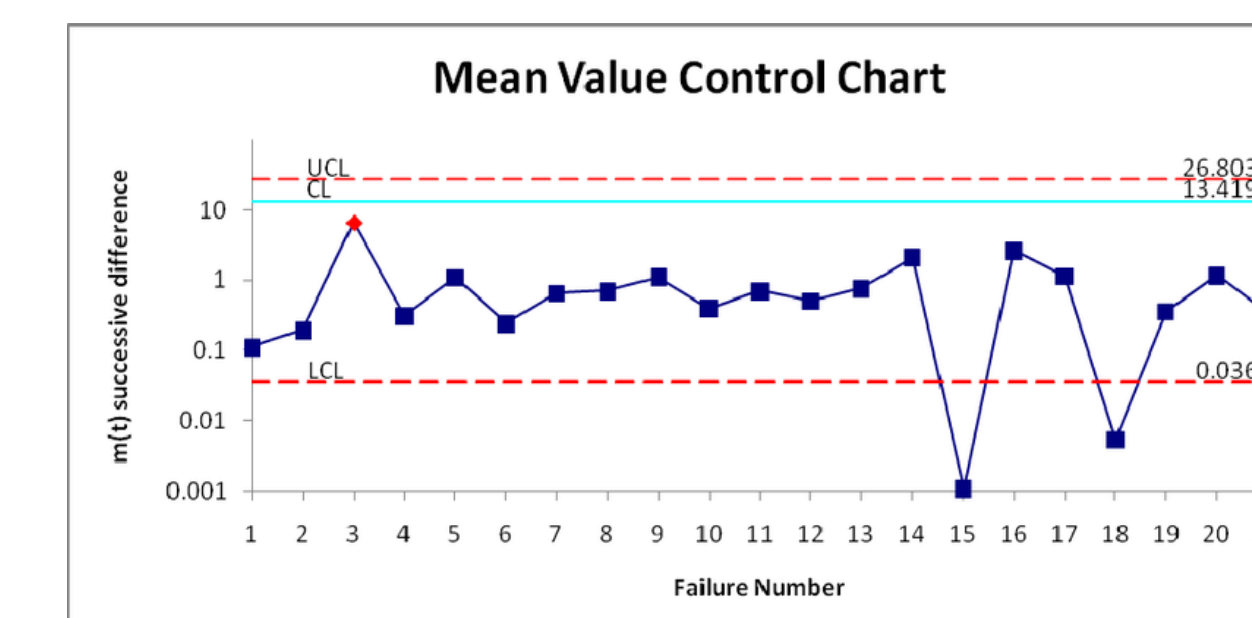

Traditionally, fault detection was accomplished through the rudimentary practice of limit checking. This method was adequate for detecting faults, but gave no instruction on where or why the fault was occurring.

### Example Model Based Approach

Consider the structured residual model presented in "Model-based Diagnosis of an Automotive Electric Power Generation and Storage System." by A. Scacchioli et al.

The 1's in the schematic indicate which residuals are sensitive to each fault. In residual evaluation, the residual corresponding to field voltage is proven to be sensitive to the Belt Slippage fault. This relationship was mentioned in section "Common Alternator Faults".

### Fault Diagnosis with Model Based Approach

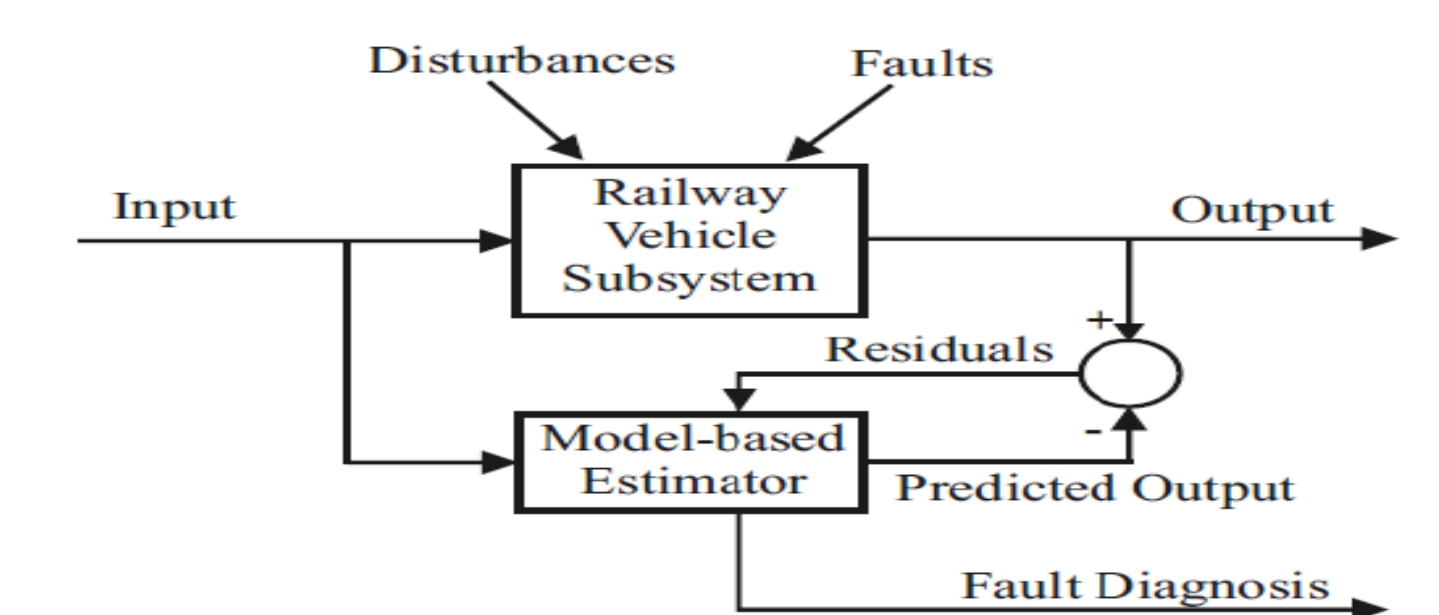

Model based FDD involves expressing the system with mathematical process models. The difference between the signals from the tester and the model's estimated signals are compared in attempt to detect and diagnose faults.

### Residuals

$$\begin{aligned}r_1 &= (I_{dc} - I_{dc}^{eq}) / I_{dc}^{nom} \\ r_2 &= (V_f - V_f^{eq}) / V_{ref}^{nom} \\ r_3 &= (V_{dc} - V_{dc}^{eq}) / V_{ref}^{nom}\end{aligned}$$

### FDD Schematic

$r_1$	$r_2$	$r_3$	Fault Type
0	1	0/-1	Belt slippage
0	x	1	Voltage regulator (increased $V_{ref}$ )
0	0	-1	Voltage regulator (drop $V_{ref}$ )
1	x	x	Power Electronics (diode fault)
0	0	0	None