

# Fault Detection and Diagnosis for Internal Combustion Engines

Centre for Mechatronics and Hybrid Technology (CMHT)

Mechanical Engineering, McMaster University

Ahmed Doghri

EECOMOBILITY (ORF) &

HEVPD&D CREATE

## INTRODUCTION

This project pertains to the development of a Fault Detection and Diagnosis System (FDD) that facilitates the detection, isolation, and identification of different fault signatures in the Internal combustion engine (ICE).



FDD systems should provide real-time diagnosis of a running ICE while being affordable, portable, and user Friendly.

## THE SENSORY SYSTEM (Hardware)

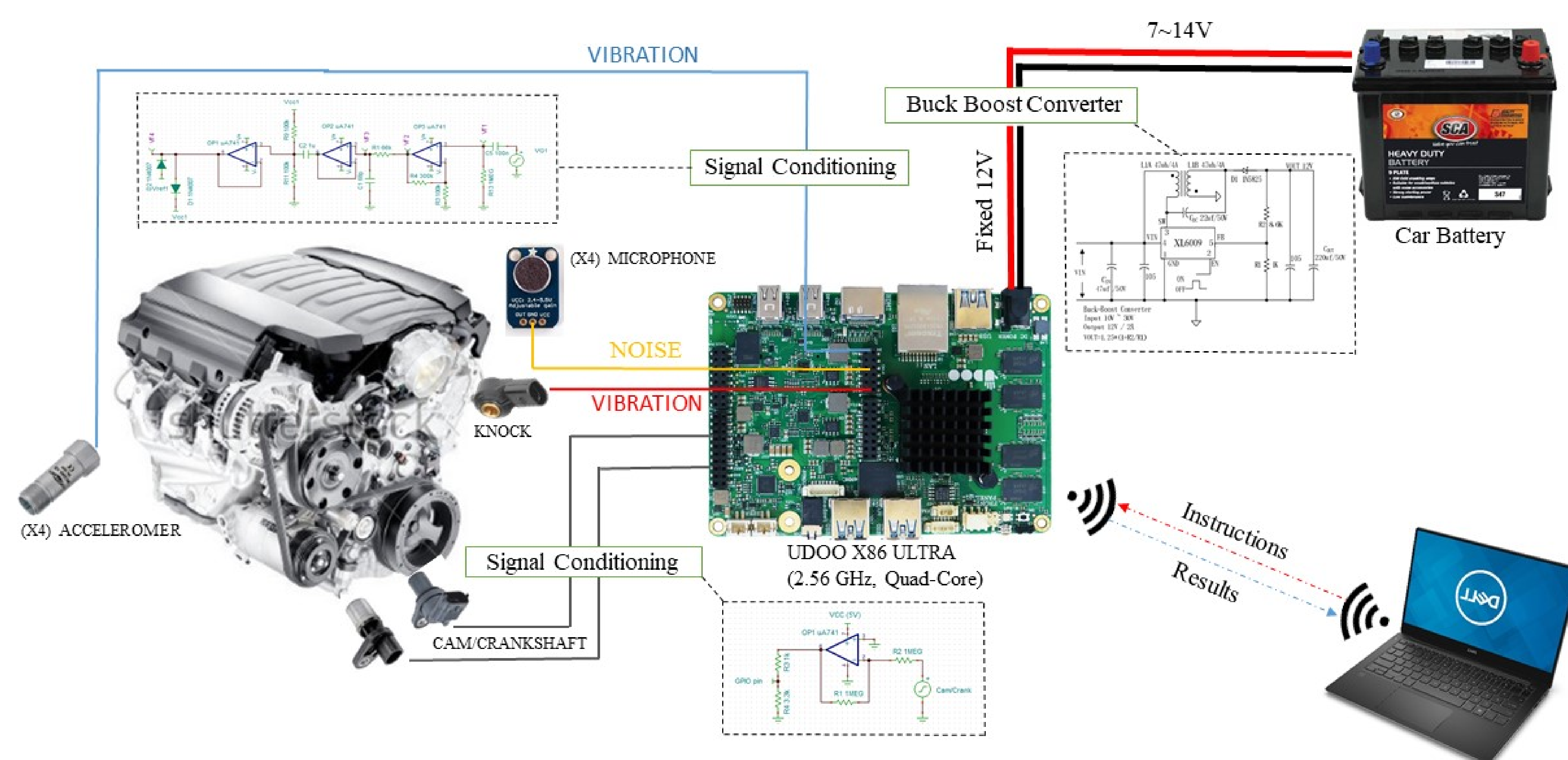

## CAD-IEMSPCA (Signal Processing Software)

The system uses the Industrial Extended Multi-Scale Principle Components Analysis (IEMSPCA) Algorithm that analyses signals in both time and frequency domains to detect any deviations from baseline measurements. If there is a deviation, The software generates faults signatures used to diagnose the fault type.

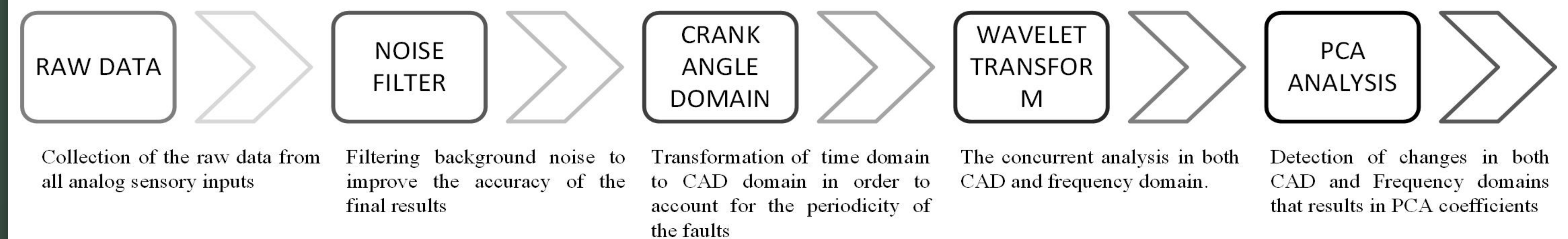

## DEEP LEARNING AI (Classification Software)

• **Deep learning** in Neural Networks is part of a broader family of machine learning methods.

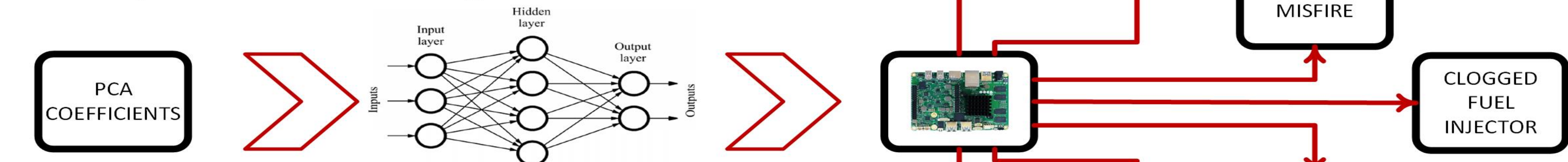

• In its core, it uses a cascade of multiple layers of nonlinear processing units for feature extraction and transformation. Each successive layer uses the output from the previous layer as input.

## RESULTS

- Small, light, and modular Sensory System
- Cloud based API to maximize the learning throughput from many cars
- Expandability over both Hybrid and Electric car models